



**ROOFING & PROFILES (FIJI) PTE LTD**

**Build With Confidence**

# 1 Degree®

Profiles Tested for Cyclonic Conditions



**Colorbond®**

✉ [info@roofingandprofiles.com.fj](mailto:info@roofingandprofiles.com.fj)

🌐 [www.roofingandprofiles.com.fj](http://www.roofingandprofiles.com.fj)

## RPFL 1Degree® Roofing Profile

Crafted for strength and built to last, RPFL 1Degree® offers unmatched durability and exceptional waterproofing capabilities, ensuring your structures are protected against the elements. With its smart fluted pans and innovative lock-action rib design, RPFL 1Degree® adapts seamlessly to low-pitched roofs, delivering both performance and aesthetics. Elevate your construction projects with a cladding solution that combines form and function, backed by the quality you can trust.

### Specifications

**Profile:** RPFL 1Degree® Roofing Profile

**Material:** G300 & G550 Steel Coated with AZ150 or AZ200 Zinalume, Z450 Hot Dipped Galvanized and Aluminium Substrate.

**Coating Options:** Colorbond®, Zinalume®, Galvanised

**Thickness:** 0.48bmt, 0.55bmt, 0.90bmt (Aluminium Only)

**Minimum Roof Pitch:** 1° (1 in 50)

**Length:** Customizable to suit your project requirements

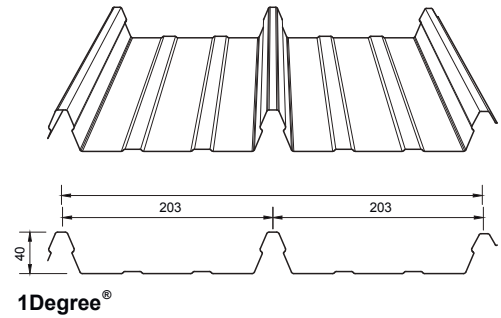

### Warranty

As per New Zealand Steel Specification & Installation Guide - March 2011.

Note: Warranty will only be provided on Colorbond® XRW®, Colorbond® Ultra® & Colorbond® Altimate® products.

### Features

Resistant to extreme weather conditions

Excellent water shedding

Easy installation

Excellent structural strength



### Why Choose RPFL 1Degree®

**Proven Performance:** RPFL 1Degree® has been extensively tested to ensure superior performance and longevity.

**Custom Solutions:** We offer a range of customization options to meet your specific project requirements, including different thicknesses, coverage widths, and lengths.

**Expert Support:** Our team of roofing professionals is ready to assist you throughout the entire process, from selecting the right profile to providing installation guidance.

**Industry-Leading Warranty:** We stand behind the quality of RPFL 1Degree® profile with a comprehensive factory backed warranty, demonstrating our commitment to customer satisfaction.

### Experience RPFL 1Degree® in Colorbond® XRW®, Colorbond® Ultra® & Colorbond® Altimate®

**Colorbond® XRW®** is a world leader in roofing and wall cladding applications, **Colorbond® XRW®** with Zinalume AZ150 Substrate provides ultimate protection against the elements in moderate and inland environments.

**Colorbond® Ultra®** delivers superior resistance to corrosion, especially in coastal and severe environments, the Zinalume AZ200 substrate enables us to offer extended warranties to your next project.

**Colorbond® Altimate®** is a marine grade aluminium substrate with the tried and tested Colorbond paint system. Designed for superior corrosion protection, Altimate® is the ideal roofing and cladding solution for extreme conditions.

Contact us today to learn more about the availability of RPFL 1Degree® in **Colorbond® XRW®**, **Colorbond® Ultra®** and **Colorbond® Altimate®** and discover how it can enhance your next roofing project.

#### Colorbond Colour Chart

##### Colorbond XRW® 0.48BMT



Deep Ocean



Iron Bark



Pale Eucalyptus



Woodland Grey



Shale Grey



Surfmist



Stone

##### Colorbond Ultra® 0.48BMT



Surfmist



Windspray

\*The colours you see on screen will vary from actual product colours. We recommend ordering a colour sample to view in natural light before making your final colour selection.



**ROOFING & PROFILES (FIJI) PTE LTD**  
Build With Confidence

✉ info@roofingandprofiles.com.fj

🌐 www.roofingandprofiles.com.fj

**1Degree®**

V1-23

## Technical Specifications

Maximum Roof Lengths for Drainage - Rainfall						
Peak Rainfall Intensity	Roof Slope					
	1°	2°	3°	5°	7.5°	10°
100	373	465	546	680	811	932
150	248	309	363	452	540	621
200	186	232	272	339	404	465
250	148	185	217	271	323	372
300	123	154	181	225	269	309
400	92	115	135	168	201	232
500	73	91	108	134	161	185

Thermal Expansion And Contraction Of Steel Cladding			
Sheet Length (mm)	Expansion Or Contraction (mm)		
	10° Change	50° Change	75° Change
5000	0.6	3	4.5
10000	1.2	6	9
15000	1.8	8	13.5
20000	2.4	12	18
25000	3	15	22.5
30000	3.6	18	27

Base Materials		Tolerance	
Steel Grade	G550 & G300	Length	+2mm, -2mm
Coating	AZ150, AZ200 & Z450	Width	+2mm, -2mm
Aluminium Alloy	5005H34 / 5052H36		

Base Metal Thickness		BMT Mass	
0.48mm	0.53TCT	0.48mm	5.5kg/m <sup>2</sup>
0.55mm	0.60TCT	0.55mm	6.5kg/m <sup>2</sup>

\*Note that TCT on above table is for Colorbond® range, TCT will vary for unpainted products. 0.90mm is available in Aluminium only.

Sheet Coverage																		
Width Of Room (m)	3	4	5	6	7	8	9	10	11	12	13	14	15	16	17	18	19	20
Number Of Sheets	8	10	13	15	18	20	23	25	28	30	33	35	37	40	42	45	47	50

## Recommended Fasteners

We recommend BRA Fasteners type with new superior B8 coating protection to AS 3566 minimum Class 4 with 25mm diameter Marine Grade Aluminium/ EPDM universal BRA Cyclone washer (Specially designed cyclone washer). BRA Fasteners exclusively available at RPFL.

## Important Publications

For your installation to perform to its full potential, it is essential that it is designed, installed and maintained in accordance with good trade practice. Please refer to:

- NZ Steel Specification & Installation Guide March 2011.
- NZ Metal Roof & Wall Cladding code of practice version 3.0 / June 2021.

## For Best Results

These suggestions will improve the appearance of the RPFL 1Degree® Roof and make installation easier.

- Keep the roofing sheets dry when closely stacked OR keep the sheets well ventilated if subjected to wet condition.
- Care should be taken to avoid dragging sheets which will cause scratching and scouring to the coated surface.
- Always walk over battens / purlins positions and wear soft soled shoes.
- Lay sheets from right to left to ensure tight fitting. Note that the trailing edge of any sheet should not be fixed until the following sheet is installed beneath it.
- Ensure the sheets are not bent unintentionally at the steps during handling.
- Install sheets with fasteners at the eave and ridge only until all sheets have been installed. Fix the roof permanently in position using the required fastener frequency.
- Heads of fasteners to be matching colour-available from RPFL.
- When cutting or trimming RPFL 1Degree® sheets, use large metal snips.
- Metal abrasive/ cutting discs should NOT be used at any time.
- Turn up sheet ends at ridges and hips and cover with suitable accessories.
- All accessories should be installed in accordance with good plumbing practice.
- On a daily basis always clean and sweep roof with soft broom and gutters free from pop rivets, loose screws and swarf to avoid rust spots. Upon completion of works clean and wash roof with soft broom.





# PROJECTS

Profile: **RPFL 1Degree®**  
Finish: **Deep Ocean Colorbond® steel**



## Residential Projects With RPFL 1 Degree® Corrugated Roofing Profile

Whether you're building a new house or renovating an existing one, RPFL 1Degree® corrugated roofing profile offers exceptional durability, versatility, and timeless style to elevate the aesthetic appeal and safeguard your investment.

### Why Choose RPFL 1 Degree® For Your Residential Project?

**Enhanced Curb Appeal:** RPFL 1Degree® corrugated design adds character and visual appeal to your home, making it stand out in the neighborhood.

**Superior Protection:** Invest in a roofing solution that provides unmatched durability and safeguards your home from the elements, giving you peace of mind.

**Expert Guidance:** Our team of roofing professionals can provide guidance throughout the project, from material selection to installation techniques, ensuring a smooth and successful experience.

**Industry-Leading Warranty:** We stand behind the quality of our RPFL 1Degree® profile with a comprehensive warranty, showcasing our commitment to customer satisfaction.



**ROOFING & PROFILES (FIJI) PTE LTD**  
Build With Confidence

✉ [info@roofingandprofiles.com.fj](mailto:info@roofingandprofiles.com.fj)

🌐 [www.roofingandprofiles.com.fj](http://www.roofingandprofiles.com.fj)

**1Degree®**

V1-23

## 1. Cyclonic Testing of 0.48bmt RPFL 1 Degree® G550 Steel Grade, Fixed to Timber Purlins

### (Cyclic wind load to NCC 2016 LHL)

Testing on RPFL 1 Degree® roofing profile was carried out by the NATA accredited Cyclone Testing Station located at the James Cook University, Townsville, Queensland, Australia.

James Cook University have provided the following reports in relation to the test results for the cyclonic testing of the 0.48bmt RPFL 1 Degree® Roofing Profile:

- Report NO. TS1077. Revision A, Cyclic Simulated Wind Load Strength Testing of Roofing & Profiles (Fiji Ltd) 0.48bmt RPFL 1 Degree® Roofing Profile Cladding for Roofing Applications, dated 19 October 2017.
- Est Summary Sheet – TS1077 Revision A, Part b dated 19 October 2017.

### Lo-Hi-Lo Cyclonic Wind Uplift Resistance Strength Limit - State Test Results Load Span Table

- 0.48bmt, G550 steel grade, cover width of 406mm.
- MGP10 timber rafter with 140mm x 45mm cross section.
- 14g x 10 thread per inch Type 17 screws with length of 90mm, with Cyclone washer, with EDPM seal under the head of the screw Class 4 minimum.

#### Load Span Table

End Span (mm)	Recommended Cyclonic Ultimate Limit State Design Wind Capacity End Span (kPa)	Internal Span (mm)	Recommended Cyclonic Ultimate Limit State Design Wind Capacity Internal Span (kPa)
600	10.15 kPa	750	10.15 kPa
750	8.68 kPa	950	8.68 kPa
950	6.03 kPa	1200	6.03 kPa

## 2. Cyclonic testing of 0.48bmt RPFL 1 Degree® G550 Steel Grade, Fixed to Steel Purlin

### (Cyclic Wind Load to NCC 2016 LHL)

Testing on RPFL 1 Degree® Roofing Profile was carried out by the NATA accredited Cyclonic Testing Station located at the James Cook University, Townsville, Queensland, Australia.

James Cook University have provided the following reports in relation to the test results for the cyclonic testing of 0.48bmt RPFL 1 Degree® Roofing Profile.

- Report No. TS1077. Revision A, Cyclic Simulated Wind Load Strength Testing of Roofing and Profiles (Fiji) Ltd 0.48bmt RPFL 1 Degree® Roofing Profile Cladding for Roofing Applications, dated 19 October 2017.
- Test Summary Sheet – TS1077 Revision A, Part a dated 19 October 2017.

### Lo-Hi-Lo Cyclonic Wind Uplift Resistance - Strength Limit State Test Results Load Span Table

- 0.48bmt, G500 Steel Grade, cover width of 406mm.
- Minimum steel purlin thickness: 1.5mm bmt, G450 Steel Grade Z450
- 14g x 10 threads per inch self-drilling metal screws, 95mm long with Cyclone washer with EDPM seal under the head of the screw Class 4 minimum.
- Fixed to support with one fastener every rib.

#### Load Span Table

End Span (mm)	Recommended Cyclonic Ultimate Limit State Design Wind Capacity End Span (kPa)	Internal Span (mm)	Recommended Cyclonic Ultimate Limit State Design Wind Capacity Internal Span (kPa)
600	10.15 kPa	750	10.15 kPa
750	7.86 kPa	950	7.86 kPa
950	5.12 kPa	1200	5.12 kPa



### **3. Cyclonic Testing of 0.55bmt RPFL 1Degree® G300 Steel Grade, Fixed to Timber Purlins (Cyclic Wind Load to NCC 2016 LHL)**

Testing on RPFL 1 Degree® roofing profile was carried out by the NATA accredited Cyclonic Testing Station located at the James Cook University, Townsville, Queensland, Australia.

James Cook University have provided the following reports in relation to the test results for the cyclonic testing of the 0.55bmt RPFL 1 Degree® Roofing Profile:

- Report No. TS1077. Revision A, Cyclic Simulated Wind Load Strength Testing of Roofing & Profiles (Fiji Ltd) 0.55bmt RPFL 1 Degree® Roofing Profile Cladding for Roofing Applications, dated 10 October 2017.
- Test Summary Sheet -TS1077 Revision A, Part B dated 19 October 2017.

#### **Lo-Hi-Low Cyclonic Wind Uplift Resistance – Strength Limit State Test Results Load Span Table**

Description of Cladding and Set-Up Tested

- 0.55bmt, G300 Steel Grade, cover width of 406mm.
- MGP10 Timber rafters with 140mm x 45mm cross section.
- 14g x 10 thread per inch Type 17 screws with length of 90mm, with Cyclone washer, EDPM seal under the head of the screw Class 4 minimum.
- Fixed to supports with one fastener every rib.

#### **Load Span Table**

End Span (mm)	Recommended Cyclonic Ultimate Limit State Design Wind Capacity End Span (kPa)	Internal Span (mm)	Recommended Cyclonic Ultimate Limit State Design Wind Capacity Internal Span (kPa)
750	10.15 kPa	950	10.15 kPa
950	6.54 kPa	1200	6.54 kPa
1200	6.53 kPa	1500	6.53 kPa

### **4. Cyclonic Testing of 0.55bmt RPFL 1 Degree® G300 Steel Grade, Fixed to Steel Purlins (Cyclic Wind Load to NCC 2016 LHL)**

Testing on RPFL 1 Degree® roofing profile was carried out by the NATA accredited Cyclonic Testing Station located at the James Cook University, Townsville, Queensland, Australia.

James Cook University have provided the following reports in relation to the test results for the cyclonic testing of the 0.48bmt RPFL 1 Degree® Roofing Profile:

- Report No. TS1077. Revision A, Cyclic Simulated Wind Load Strength Testing of Roofing & Profiles (Fiji Ltd) 0.48bmt RPFL 1 Degree® Roofing Profile Cladding for Roofing Applications, dated 10 October 2017.
- Test Summary Sheet -TS1077 Revision A, Part b dated 19 October 2017.

#### **Lo-Hi-Low Cyclonic Wind Uplift Resistance – Strength Limit State Test Results Load Span Table**

- 0.55bmt, G550 Steel Grade, cover width of 406mm.
- Minimum steel purlin thickness, 1.5mm bmt, G450 Steel Grade Z450.
- 14g x 10 threads per inch self-drilling metal screws, 95mm long with Cyclone washer with EDPM seal under the head of the screw Class 4 minimum.
- Fixed to supports with one fastener every rib.

#### **Load Span Table**

End Span (mm)	Recommended Cyclonic Ultimate Limit State Design Wind Capacity End Span (kPa)	Internal Span (mm)	Recommended Cyclonic Ultimate Limit State Design Wind Capacity Internal Span (kPa)
750	8.39 kPa	950	8.39 kPa
950	8.27 kPa	1200	8.27 kPa
1200	6.53 kPa	1500	6.53 kPa



**Notes:**

- It is recommended that a local qualified structural engineer check the suitability of the provided Ultimate Limit State Design Wind Capacities provided in the load span table for the intended use/structure and site location.
- It is recommended that in the event of an extreme storm/extreme winds the cladding is inspected by a suitably qualified builder/engineer to confirm the adequacy of the cladding and fasteners post event.
- It is our opinion that a qualified structural engineer may extrapolate for shorter spans and higher pressures provided that the screw force is not exceeded.
- After exposure of cladding to an extreme wind event, it is recommended that inspection be performed to confirm fixing and cladding integrity.

We, Gama Consulting Pty Ltd., confirm that the procedures used in carrying out the cyclonic load tests on product as listed above from for Roofing & Profiles (Fiji) Ltd., confirm the testing program has been carried out in accordance with the requirement of the National Code Construction Series (NCC, 2016). The results listed in the load span table above conform to the structural requirements of NCC and the following Australian Standards.

- AS 1562.1 – 1992 (Amdt 3 - 2012): Design and Installation of sheet roof and wall cladding.
- AS 4040 – 1992: Methods of testing sheet roof and wall cladding.
- Part 0 : Introduction, list of methods and general requirements.
- Method 3: Methods of testing sheet roof and wall cladding – Resistance to wind pressures for cyclone regions, pressure test regime as per BCA Lo-Hi-Lo.

## **5. Windborne Debris Impact Testing on 0.48bmt RPFL 1 Degree® G550 Roofing Profile** **Roof application – Vertical Trajectories**

The Wind Debris Impact Testing program (Vertical Trajectories) for the 0.48bmt RPFL 1 Degree® G550 Roofing Profile was carried out by the NATA accredited Cyclone Testing Station located at the James Cook University, Townsville, Queensland, Australia.

James Cook University have provided the following reports in relation to the test results for the Wind Debris Impact Testing program (Vertical Trajectories) of the 0.48bmt RPFL 1 Degree® Roofing Profile:

- Report NO. TS1079.Revision A, Simulated Wind Debris Impact Testing of RPFL 1 Degree® Profile Cladding of Roofing & Profiles (Fiji Ltd) 0.48bmt RPFL 1 Degree® Roofing Profile Cladding for Roofing Applications, dated 19 October 2017.
- Test Summary Sheet – TS1079 Revision A, Part a dated 19 October 2017.

### **Description of Cladding and Set-Up Tested**

- 0.48bmt, G550 steel grade, cover width of 406mm.
- Minimum steel purlin thickness, 1.5mm bmt, G450 steel grade Z450.
- 14g x 10 threads per inch self-drilling metal screws, 95mm long with Cyclone washer with EDPM seal under the head of the screw Class 4 minimum.
- Fixed to supports with one fastener every rib. Wind Debris Impact Test Results

Target Velocities:

Timber member of 4kg mass (100x50mm)

Spherical steel ball 8mm diameter (approx. 2g mass)

Tested Spans:

Triple Span: 480mm Single Span: 1500mm





## **6. Windborne Debris Impact Testing on 0.55bmt RPFL 1 Degree® G300 Roofing Profile**

### **Roof application – Vertical Trajectories**

The Wind Debris Impact Testing program (Vertical Trajectories) for the 0.55bmt RPFL 1 Degree® G300 Roofing Profile was carried out by the NATA accredited Cyclone Testing Station located at the James Cook University, Townsville, Queensland, Australia.

James Cook University have provided the following reports in relation to the test results for the Wind Debris Impact Testing program (Vertical Trajectories) of the 0.55bmt RPFL 1 Degree® Roofing Profile:

- Report NO. TS1079.Revision A, Simulated Wind Debris Impact Testing of RPFL 1 Degree® Profile Cladding of Roofing & Profiles (Fiji Ltd) 0.55bmt 1 Degree® Roofing Profile Cladding for Roofing Applications, dated 19 October 2017.
- Test Summary Sheet – TS1079 Revision A, Part b dated 19 October 2017.

#### **Description of Cladding and Set-Up Tested**

- 0.55bmt, G300 steel grade, cover width of 406mm.
- Minimum steel purlin thickness, 1.5mm bmt, G450 steel grade Z450.
- 14g x 10 threads per inch self-drilling metal screws, 95mm long with Cyclone washer with EDPM seal under the head of the screw Class 4 minimum.
- Fixed to supports with one fastener every rib.

#### **Wind Debris Impact Test Results**

##### **Target Velocities:**

Timber member of 4kg mass (100x50mm)

Spherical steel ball 8mm diameter (approx. 2g mass)

##### **Tested Spans:**

Triple Span: 480mm Single Span: 1500mm

##### **Notes:**

- It is recommended that in the event of an extreme storm/extreme winds the cladding is inspected by a suitably qualified builder/engineer to confirm the adequacy of the cladding and fasteners post event.

We, Gama Consulting Pty Ltd., confirm that the procedures used in the testing program has been carried out in accordance with the requirement of the National Code Construction Series (NCC, 2015). The results listed above for the Wind Debris Impact Testing for vertical trajectories only conform to the structural requirements of NCC and the following Australian Standards.

- AS 1170.2 – 2011: Structural Design Actions, Part 2: Wind actions.

