

Vent seal against flashing

RPFL Std Colorbond® XRW/Ultra 0.55 BMT L  
Shaped Flashing. Base Materials: coating  
AZ150/AZ200 Steel Grade G300. fixed to cladding  
with SDM screws

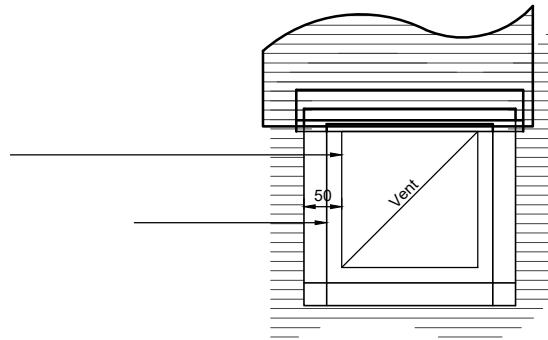

**Note:**

These details are suitably fixed to allow for a theoretical thermal movement of up to 10mm. For thermal movement greater than this a clipping system should be considered.

RPFL SuperDek® Colorbond® XRW/Ultra 0.42BMT/0.48BMT  
roof cladding. Base Materials: Steel Grade G550. BMT  
0.42. Mass 4.3kg/m<sup>2</sup> or 0.48BMT 4.9kg/m<sup>2</sup>. AZ 150 coating for  
XRW & AZ 200 coating for Ultra. Minimum Roof Pitch 2  
degree. Profiles tested for Cyclonic Conditions.

RPFL Std Colorbond® XRW/Ultra 0.55 BMT Head Flashing.  
Base Materials: coating AZ150/AZ200 Steel Grade G300.  
fixed to the roof cladding with SDM screws

Vent seal against flashing

RPFL Std Colorbond® XRW/Ultra 0.55 BMT Head  
Flashing. Base Materials: coating AZ150/AZ200 Steel  
Grade G300. fixed to cladding with SDM screws

Flashguard Soft Edge flashing for  
metal roof accessories

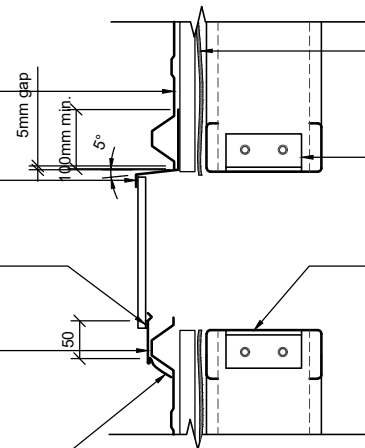

Kingspan AIR-CELL Insulbreak @65 R2.4  
Self-Supported 3-in-1 Insulation Vapour Barrier and  
Radiant Barrier

RPFL Zed & Cee sections fixed with Self Teking Screws SDM  
14-20x22 HEX SL Conformance Std AS3566, Self teking screws  
for valley fixing and Galv. Purlin to Galv. Bracket connection.

RPFL Zed & Cee sections are roll formed from  
GALVSTEEL, complying with AS1397-2001. Metal  
thickness is 1.5, 1.9 & 2.4mm. BMT G450, Z450.



ROOFING & PROFILES (FIJI) LTD  
PH: (679) 6673764. Mob: 9999 309  
EMAIL: info@roofingandprofiles.com.fj

This drawing is the property of Roofing & Profiles (Fiji) Ltd and must not be copied or disclosed to any third party without the written consent of the company.  
ALL DIMENSIONS ARE IN mm UNLESS STATED

PROJECT TITLE:  
VENT DETAILS

DRAWING TITLE:  
SHOP DRAWING

Nos:	Revision:		
1.			
2.			
3.			
4.			
5.			

DRAWN: R. Lal

DATE: 04/01/2021

CHECKED BY: -

SCALE: 1:7.5 @ A4

REVISION No:

APPROVED BY: -

SHEET No: SD 2250

REVISION TITLE:

JOB NUMBER: